

Miss Rodeo Idaho 2012 Contest Rules



Royally Promoting Our Western Way of Life

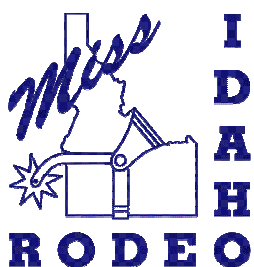

TABLE OF CONTENTS

About Miss Rodeo Idaho

- *Miss Rodeo Idaho Since 1956*
- *Contestant Eligibility*
- *Entry Procedures*

General Pageant Guidelines

1. *Conduct of Contestants*
2. *Crowns and Banners*
3. *Pageant Orientation*
4. *Contract*
5. *Scholarship Fund Administration*
6. *Housing & Food*
7. *Cell Phone/Electronic Device Usage*
8. *Transportation*
9. *Chaperones*
10. *Parents, Relatives and Friends*
11. *Horses*
12. *Dress*
13. *Awards Presentation*
14. *Awards*
15. *MRI and MRI Elect*
16. *Score sheets*
17. *Grievances*

Judging Guidelines

Judged Categories/Events

- *Horsemanship*
- *Personality*
- *Appearance*
- *Speech*
- *Modeling*
- *Private Interviews*
- *Extemporaneous Questions*
- *Photogenic Quality*
- *Parade*
- *Media Interview*
- *Photogenics*
- *Test*

Appendices

- A. *Dress Code for Pageant Events*
- B. *Horsemanship Patterns*

The Miss Rodeo Idaho Pageant Official Rulebook is reviewed and updated on an annual basis by the Miss Rodeo Idaho Inc. Board of Directors. Questions and suggestions can be addressed to the Board at any time.

MISS RODEO IDAHO

Royally Promoting Our Western Way of Life

Miss Rodeo Idaho, hereinafter referred to as MRI, symbolizes the youth of our state who wish to further promote the sport of rodeo, and in so doing, promote our western heritage. She is the ideal western American young woman, and will represent our state and the sport of rodeo as she travels throughout Idaho and the country. Miss Rodeo Idaho will represent her state at the Miss Rodeo America Pageant.

While spreading good will for her community and her state, MRI is garnering the richest experience of her life, and is laying a solid foundation for her future. She receives gifts and donations from sponsors to assist with her expenses as she travels and promotes the great sport of rodeo.

Karen Thorson	1956-57	Neenie (Blake) Corr	1984-85
Kay (Weick) Dennis	1957-58	Michelle (Kelley) Warner	1985-86
Susan (Cox) Stauffer	1958-59	Lisa (Lemrick) Boggs	1986
Carolyn (Wyllie) Cutler	1959-60	Nicole Hyman	1987
Donna (Fletcher) Crow	1960-61	Suzanne (Tomtan) Stancil	1988**
Karen (Lavens) James	1961-62*	Joni (James) Smith	1989
Nancy Sheldon	1962-63	Rhonda (Vedvig) Bright	1990
Parttie Anne (Nally) Lodge	1963-64	Andrea Schlapia	1991
Bonnie Bruning	1964-65	Julia (Christensen) Shoemaker	1992
Harriet (Sharp) Gleason	1965-66	Crista (Madsen) Smith	1993
Rosemary (Vassar) Weaver	1966-67	Carrie (Johnson) Wilson	1994
Yo (Willhite) Marts	1967-68	Laura Hadley	1995
Jackie (Bodenhofer) Brown	1968-69	Kimberly (Williams) Brackett	1996**
Carolyn (Harvey) Doherty	1969-70	Margaux (Edwards) Crockett	1997
Lana (Brackenbury) Parker	1970-71*	Shelly Williams	1998*
Ruth (Campbell) Schneider	1971-72	Selbi Board	1999
Lola (Anglin) Else	1972-73	Kindi Hess	2000
Jody (Walchel) Cada	1973-74	Britny (Christensen) Field	2001
Christine (Doherty) Holmes	1974-75	Gabrielle (James) Rhoades	2002
Betty (Schnell) Freeman	1975-76*	Amanda Kent	2003
Claudia (Pence) Dains	1976-77	Ali (Swan) Shiozawa	2004
Candy (Robertson) Grossaint	1977-78	Stefanie Glore	2005
Susan (Carter) Rood	1978-79	Scharlee Roberts	2006
Diana (Rackham) Nielsen	1979-80	Morgan Anselmi	2007
Anna (Wagner) Casperson	1980-81	Natalie Bish	2008
Sharon (Cook) Chivers	1981-82	Freya Ford	2009
Vicki (Rutledge) Shields	1982-83	Measha Gittins	2010
Myla (Meiers) Nallion	1983-84	Tricia Crump	2011
		*Denotes Miss Rodeo America	
		**Denotes Miss Rodeo USA	

CONTESTANT ELIGIBILITY

Each contestant in the MRI Pageant shall comply with the following effective on the date of competition. Contestants must:

- A. I am a female and have always been a female
- B. Must be at least 19 years of age and not 25 years of age or older and will not have attained age 25 as of December 31st of the pageant year.
- C. Have a high school diploma or the equivalent of a high school education.
- D. Be a resident of the state of Idaho for a period for at least six months prior to the pageant. MRI Elect must maintain that residency throughout her MRI reign.
- E. It is recommended to be sponsored by an Idaho rodeo committee or a recognized organization such as a service club, chamber of commerce, sheriff's posse, riding club, etc. Sponsors will be recognized on contestant banners, tear sheets, programs, etc...
- F. Not have been a previous MRI, any other state's "Miss Rodeo," hold any other state title for any pageant, or competed or previously competed in the Miss Rodeo America Pageant. If the contestant holds another title which has not expired prior to assuming responsibilities as MRI, she will forfeit that title and will not be allowed to wear any other crown or banner but MRI if she is chosen as such.
- G. Must be a single woman and shall never have been married, had a marriage annulled, or ever been pregnant. She must not cohabit with a boyfriend or member of the opposite sex (excluding relatives) during her reign. She must not be engaged at any time during the pageant or time of her reign if awarded MRI title.
- H. Must abide by all rules and regulations of the MRI Pageant.
- I. Must execute and provide all consents, waivers, agreements, documentation and/or code of conduct as presented as conditions precedent to competition and as detailed in the application packet. MRI, Inc. reserves the right to disqualify any contestant for rule infractions.
- J. Must not have been charged with and/or determined to have committed any crime of moral turpitude.
- K. Must not have taken any actions, which in the good faith determination of the Board of MRI, Inc. will or is reasonable likely to cause harm or damage to the goodwill or reputation of MRI, Inc.

Any contestant not meeting the qualifications set forth above shall be denied the right to compete in the Miss Rodeo Idaho Pageant.

ENTRY PROCEDURES

- A. Each contestant must complete an official MRI entry application.
- B. The non-refundable Pageant entry fee must be paid by the sponsoring organization and accompany the entry application.
- C. MRI Inc. must receive entry application at the address indicated on the application. Applications postmarked later than the closing date provided will be disqualified. There are no exceptions.
- D. The following will be required with the application:
 - 1. Non-refundable entry fee (\$450.00)
 - 2. Signed MRI Pageant Application Form
 - 3. Release Disclosures and Warnings
 - 4. Assumptions of Risk and Release
 - 5. Scholarship Letter of Understanding
 - 6. Waiver of Liability
 - 7. Personal Statistics Form
 - 8. Code of Conduct
 - 9. Medical Information Form
 - 10. Copy of Driver's License
 - 11. Proof of High School Education or Equivalent

GENERAL PAGEANT

CONDUCT OF CONTESTANTS

1. MRI contestants and titleholders are expected to conduct themselves in an exceptional manner. Unsportsmanlike conduct will not be tolerated. Such conduct could result in the contestant being disqualified and may affect eligibility to compete in future MRI Pageants.
2. Harassment and arguing between contestants will not be tolerated.
3. A judge may not be approached by a contestant or any individual with the intent to influence or harass. Action of this type will be reported to the MRI, Inc. Board and disqualification of that contestant could result.
4. The pageant is not officially complete until contestants are checked out of their hotel room, or until the coronation is completed, whichever comes last. Contestants will be responsible for any damage done to the room.
5. Contestants are expected to abide by the MRI Pageant Contestant Code of Conduct.

CROWNS & BANNERS

Contestants will not wear a crown at any activities (unless otherwise indicated by dress code), and will be provided a Banner identifying the Contestant's sponsor by MRI, Inc.

PAGEANT ORIENTATION

Pageant orientation will be held prior to the pageant. Attendance is mandatory. Parents are welcome. Transportation to and from orientation is the sole responsibility of the contestant. The orientation may consist of the following:

1. An opportunity to meet the contestants, their parents, and the MRI Board of Directors
2. A description of pageant activities with the opportunity to ask questions and receive answers about those activities
3. Drawing for the order of a contestant's appearance in all pageant activities.

CONTRACT

A copy of the contract the winner will be required to sign will be furnished to each Contestant prior to orientation.

SCHOLARSHIP FUND ADMINISTRATION

Educational scholarships awarded during the MRI Pageant are administered by the MRI, Inc. Board of Directors. Scholarships paid by the Snake River Stampede will be paid directly by the SRS to the hosting university upon the approval of the MRI Inc. Board and the submittal of the required documentation. Rules concerning the eligibility and use of these Scholarships are provided in the Application package "Scholarship Letter of Understanding and Rules".

HOUSING & FOOD

Lodging and food will be provided for by MRI, Inc. during the pageant. All other expenses are the responsibility of the contestant. Contestants will want to have some spending money available to them during the Pageant for incidentals.

CELL PHONE USAGE

The possession of and/or use of any electronic devices i.e.: cell phones, PDA devices, laptop computers, and/or any devices with internet capabilities are strictly prohibited by contestants during the competition. In case of emergency, all inquiries must go through the head chaperone.

TRANSPORTATION

Contestants in the MRI Pageant are required to pay their own transportation to and from the site of the pageant. Transportation during the pageant needed for contestant functions outside of the hotel grounds shall be provided by MRI, Inc. for contestants only. In the event that contestants are released to their parents prior to coronation, contestants are required to arrive at MRI functions on time and appropriately dressed.

CHAPERONES

Contestants are under the supervision of, and will be escorted by the chaperones to and from ALL functions during the pageant. A Contestant's clearing house will be available to receive all congratulatory letters and telegrams, phone calls, flowers, dry cleaning, etc. Parents, relatives and friends are required to use this means to make deliveries to contestants and will not contact them directly. Please refer to the Head Chaperone for any questions.

PARENTS, RELATIVES AND FRIENDS

1. MRI, Inc. welcomes and encourages the presence of parents, relatives and friends of the contestants. No boyfriends will be permitted to fraternize with the contestants or to distract them. After the pageant begins, contestants cannot communicate with family or friends unless authorized by their chaperone. No parents will be allowed in the contestant's rooms during the pageant. At the judges' discretion, a contestant may receive point deductions or disqualification for an infraction of this rule.
2. There will be some free time for the contestants during the pageant. This time is made available for visiting with family and friends. At no time will parents, relatives, or friends of the contestants interfere with the pageant committee or MRI Inc. Board of Directors.
3. There will not be any parents, relatives, friends, trainers, etc. allowed in the horsemanship area before and during the competition. If anyone enters the warm up area or the arena or makes any other contact without permission, their contestant will be given point reductions or disqualification at the judges' discretion.

HORSES

Contestants' horses will be used for the Parade, Horsemanship Competition and presentation rides during the Rodeo. While using your own horse, you will use your own tack. Stalls will be provided during the competition at the Idaho Horse Park. You must bring your own feed. Bedding will be available to purchase at time of check-in if needed. All horses will be stalled at the Idaho Horse Park, a friend or family member will be needed to clean and feed and exercise your horse daily. While spurs will not be allowed during the Horsemanship Competition, contestants may wear spurs during the parade, rodeo presentations rides, and coronation. Contestants must use the same horse for all events including: parade, 1 go of horsemanship, rodeo presentation rides. All horses used for competition must compete in a bridle. (no snaffle bits, O ring,/D ring) **Stallions are not allowed.**

DRESS

See Appendix A for specific dress requirements for each event.

AWARDS PRESENTATION

All contestants are required to attend the Awards presentation. Contestants will wear full western attire including hat, boots, belt and banner. Should a contestant not attend the Awards presentation, or should a contestant attend without her full western attire, she will automatically forfeit her award and/or scholarship.

AWARDS

Awards will be given to high point contestants in the following categories, including Horsemanship, Speech, Personality, Photogenics and Appearance. Awards and scholarships will also be provided for MRI, the First Runner-Up, and the Second Runner-Up. Specific awards and scholarships provided in each category may and will vary from year to year. Additional awards and scholarships may be provided. The Congeniality Award will be identified by a vote of all contestants.

MRI AND FIRST RUNNER-UP

At the conclusion of the contest, the winner and the first runner-up of the Miss Rodeo Idaho pageant will be required to sign a contract between herself and Miss Rodeo Idaho Inc. The First Runner-Up will be expected to assume the role of Miss Rodeo Idaho in the event Miss Rodeo Idaho is not able to fulfill that responsibility. In that event, the First Runner-Up may or may not be provided with the same awards as originally provided to Miss Rodeo Idaho.

The winner of the Pageant will be required to compete in the Miss Rodeo America Pageant in the year of her reign. Miss Rodeo Idaho's reign will begin December 15, and will end on the 7th day after the Miss Rodeo America Pageant in which she participates.

SCORE SHEETS

Score sheets will be mailed to each contestant within 10 business days after the completion of the pageant.

GRIEVANCES

Grievances should be immediately referred to the MRI Pageant Coordinator. The MRI Pageant Coordinator and the Board have full authority over the pageant and any decision they make regarding rules and participation is final.

All grievances must be submitted in writing by a contestant to the MRI Grievance Committee within 3 hours of an incident. No other grievances will be acknowledged. The Grievance Committee shall consist of: the MRI Pageant Coordinator, MRI President, Head Judge and a Contestant Parent selected at orientation. They will utilize a fact-finding process which will include consultation with the contestant(s), the Board and the other Judges to make a determination. That determination will be considered final.

A grievance cannot be filed based on the outcome of the pageant.

JUDGING GUIDELINES

Miss Rodeo Idaho contestants are judged in three categories, all of which are equal: horsemanship, personality and appearance. Scores from a contestant's speech, photogenic quality, interview(s), extemporaneous questions, horsemanship/rodeo knowledge questions, introductions, fashion show presentation, media interview, etc., will be added within those categories. All judges will judge all categories of the pageant and all judges' scores will be used. Judging will take precedence over all pageant activities and schedules.

1. MRI will provide for three to five judges, depending upon the number of contestants.
2. Judges are selected for their expertise in all fields of the competition.
3. Judges will judge all categories of the pageant.
4. All judges' scores will be used.
5. A Head Judge will be chosen.
6. Judges may, at their discretion, deduct points if they see trainers coaching contestants from the side during the Horsemanship competition, or if they witness unsportsmanlike conduct at any time.
7. After each event, judges will hand their finished score sheets to the Head Judge, who will place the score sheet in a manila envelope. The Head Judge will seal the envelope and sign his/her name across the flap. The Head Judge is responsible for the integrity of the score sheets between the time the event ends until that time the envelope can be delivered to a CPA or auditing firm.
8. On a minimum of a daily basis, a two-person committee of MRI Inc. members will collect the sealed envelopes and deliver them to the auditing individual or firm who compiles, in private, the scores.
9. When judging in all divisions has been completed, the auditors will determine which contestants have scored the highest in each category and in the overall scores. The highest overall score will be MRI; second highest will be the first runner-up.
10. Scoring ties in Appearance, Personality, Horsemanship, Speech and Photogenics will be broken by referring back to the score of the Head Judge. That score will break the tie. If a tie still remains, the score of the next judge will be used, and so on until the tie is broken.
11. A tie for scoring for MRI (and first runner-up) will be broken by the Horsemanship scores. The contestant with the highest score in Horsemanship will receive the higher ranking.
12. The highest cumulative total of appearance scores in all judged events will win the Appearance Category; the highest cumulative total of personality scores in all judged events will win the Personality Category; the highest cumulative total of horsemanship scores in all judged events will win the Horsemanship Category. Other specific awardees will be identified as those having the highest score in that area.
13. All decisions are final.

JUDGED CATAGORIES

HORSEMANSHIP

The purpose of this judged division is to select the young lady who rates highest in:

1. Horsemanship – including control of mount and the way she handles any situation which may occur.
2. Balance – the ability to sit a saddle.
3. Positions of hands, feet and seat.
4. Mounting and dismounting.
5. Confidence, appearance, and awareness of audience.

It is not the horse, but the skill, understanding and ability of the contestant that will be judged.

Contestants will provide their own horse for the duration of the competition. See “Horses” under General Guidelines for more details about stalling and caring for contestants’ horses.

Each contestant will ride a horse in each of two go-rounds of horsemanship competition. There will be a draw for the order in which contestants and also a draw for each contestant’s mount. No contestants may ride the same horse in both go-rounds. Judges will decide

The pattern for the first go-round of Horsemanship competition will be an open free-style competition. The Contestants will be given one and a half minutes (1 ½) to show her mount to the best of her ability. **Please see details below at the end of rulebook for first go-round pattern specifics.** In the first go-round, the Contestant will ride her own horse and end the pattern with a flag presentation ride. **Note: (Please bring a flag boot with you).**

The pattern for the second go-round the contestant will ride the horse she has drawn from the other contestants’ horses to the best of her ability. The pattern will be selected by the judges just prior to the horsemanship competition from patterns numbered #1, #2, and #3 at the end of the rulebook. In the second go-round, the Contestant will end the pattern with a presentation ride.

At the Judges’ discretion, patterns may be altered. Contestants may also be required to participate in an equitation class. Any changes and/or alterations to the horsemanship patterns will be announced to the contestants before the Horsemanship competition begins. The patterns will be demonstrated by the reigning MRI.

The contestant may be required to dismount and remount, perform rail work, or change the pattern as so designated by the judges, or do free style work. The patterns should be set by the reigning titleholder, if possible. The contestants may be asked to carry a flag and/or make a presentation ride following the completion of one or both patterns.

Judges may, at their discretion, deduct points if they see trainers coaching contestants from the side.

PERSONALITY

The purpose of this judged division is to select the young lady who rates the highest in:

1. Intelligence – good common sense
2. Education – knowledge of and conversational ability in rodeo and other areas with special emphasis on grammar and enunciation.
3. Attractiveness – not necessarily to mean beauty in this sense, but rather that the contestant radiates self-confidence. She should also show maturity, high moral standards, sincerity, and integrity.
4. Personality Reflections – to include the contestant's style of attire, overall appearance, magnetism and eye appeal.
5. Genuine interest in other people in the pageant, and in rodeo – and a noticeable consideration of others.
6. Self-projection – the ability to project one's personality whether it be from horseback in the arena, on television, or before an audience. Other considerations include a sense of humor, showmanship, ambition, desire, and enthusiasm.
7. Positive outlook on life in general.
8. Sense of Humor/Outlook
9. Conversational ability
10. Extemporaneous questions – which require the contestant to think on her feet and show maturity, intelligence, wisdom, and imagination.
11. Professionalism – the contestant's ability to conduct herself in a professional manner in all aspects of competition.
12. Public Appearances – the ability to speak to an audience in an interesting manner about facts, their state, rodeo, and more.

APPEARANCE

The purpose of this judged division is to select the young lady who rates highest in:

1. Attractiveness
2. Grooming – to include neatness and cleanliness in every detail such as complexion, use of cosmetics, hands, fingernails, hair, hat, boots and other apparel.
3. Poise, posture, and lady-like behavior
4. Photogenic quality
5. Knowledge of proper western attire to include:
 - a. Color coordination and proper fit
 - b. Crease and shape of hat
 - c. Dresses, skirts, and blouses should reflect a western image. Evening gowns or cocktail type dresses are not permitted.
 - d. Contestants are expected to appear in full western attire at all times unless otherwise specified. This includes Wrangler pants or jeans, dresses, skirts, blouses, jackets, hats, boots, belt.
 - e. Dress should always be appropriate for the occasion.
 - f. Knowledge of current trends in western wear manufacturing.

JUDGED EVENTS

SPEECH

The purpose of this judged division is to select the contestant who rates highest in public speaking.

1. Each contestant is required to give a two-minute speech on Idaho. No props will be allowed.
2. Other judged speech events may be required.
3. Speeches will be timed. The judges will be given the length of each speech. It is important to keep to the time limit.
4. Speeches will be judged on content, delivery, appearance, and personality
5. Organization and subject relevancy to required topic.
6. Use of microphone
7. Enunciation and grammar
8. Eye contact and projection to audience
9. Initiative/Flair

MODELING

Contestants will participate in at least one fashion show. Judging criteria includes:

1. Personality
2. Appearance
3. Creativity
4. Initiative/Flair
5. Stage Presence
6. Proper Presentation
7. Self Confidence

PRIVATE INTERVIEWS

Each contestant will be interviewed privately at least twice by the judges for a minimum of 10 minutes and not to exceed 15 minutes each time. Judging criteria includes:

1. Correct answers to questions related to knowledge of the pageant, knowledge of the Pro-Rodeo World including PRCA and WPRA/PWRA (including current standings, history & organization), rodeo terminology, explanation of rodeo events, equine knowledge (including tack, horse care, feeding, diseases, anatomy, etc.) & current events.
2. Appearance
3. Personality

EXTEMPORANEOUS QUESTIONS

Questions will be asked of each contestant during pageant functions. Questions may relate to the sport of professional rodeo and/or current events. Judging criteria includes:

1. Ability to answer the question.
2. Delivery
3. Knowledge
4. Enunciation
5. Appearance
6. Personality:
 - a. ability to relate to the audience
 - b. sense of humor

PARADE

The judges will score contestants in the "Snake River Dayz Parade". Judging criteria includes:

1. Overall appearance
2. Expression-Attitude
3. Choice of colors
4. Interaction with audience

MEDIA INTERVIEW

The judges will score the media interview. Judging criteria includes:

1. Overall appearance
2. Expression-Attitude
3. Choice of colors
4. Eye contact with camera

TEST

Contestants will be required to take a written test, which will consist of questions relating to the sport of rodeo, PRCA, the Snake River Stampede and equine knowledge, etc. Tests will be scored with the highest score winning a special award. These scores will count in the total score; tests will be presented to the judges for their reference.

PHOTOGENICS

The judges will score the 8" x 10" vertical head and shoulders photograph. Judging criteria includes:

1. Overall appearance
2. Expression-Attitude
3. Choice of colors
4. Eye contact with camera

APPENDIX A DRESS CODE FOR PAGEANT EVENTS

Tentative 4/15/11

Photogenic:	Outfit of your choice, 8x10 color head- and-shoulders photo. Hat required (no crown)
Parade:	Wrangler® pant product with parade attire, tiara, banner; chaps, serape, flowers (optional) representing your sponsor.
Orientation:	Same outfit as parade
Chamber Event	Wrangler® pant product with western shirt, vest or jacket.
SRS Buckaroo Breakfast (2):	Wrangler® pant product with western shirt, vest or jacket.
Horsemanship Interview:	Wrangler® pant product; form-fitting blouse or shirt with long sleeves, any color. No vests or jacket. Hat required. (Same attire as worn for horsemanship)
Horsemanship:	Wrangler® pant product; form-fitting blouse or shirt with long sleeves, any color. No vests or jacket. Hat required.
Personal Interview:	Wrangler® pant product required with shirt, vest or jacket.
Speech:	Dress Outfit of Choice
Coronation Performance:	Outfit 1 – Will be assigned upon confirmation of your pageant participation. Outfit 2 – Western Elegance-Dress or skirt with blouse and/or jacket.

Banners furnished by MRI, Inc. are to be worn at all times. Keep this in mind when designing your outfits. No crowns will be worn (except where noted)

MRI Horsemanship Competition

Each Contestant will compete in two go-rounds of horsemanship competition. Contestants will draw for the order in which they compete and also for their mount in the second go-round. No contestant will ride the same horse in both go-rounds.

The judges will select ONE of the patterns marked Pattern #1, #2 or #3 (see attached) for the 1st go-round. For the 2nd go-round, Contestants will ride a freestyle pattern of their choosing according to the following guidelines:

Freestyle Pattern

Each contestant will be given one and a half minutes to complete the pattern. A whistle will be blown at one minute as a warning that the contestant will have thirty seconds to complete their freestyle pattern. Contestant will hesitate to show completion of pattern, and will then proceed to gate to pick up flag for flag presentation ride.

Required maneuvers will include:

- ❖ A minimum of (1) maximum of (4) consecutive spins to the left
- ❖ A minimum of (1) maximum of (4) consecutive spins to the right
- ❖ A minimum of (1) stop
- ❖ A minimum (1) lead change in both directions

Judges will ascertain if all requirements are met using the Freestyle Score Sheet. Failure to perform any of the required maneuvers will result in an arbitrary deduction of points.

Pattern 1

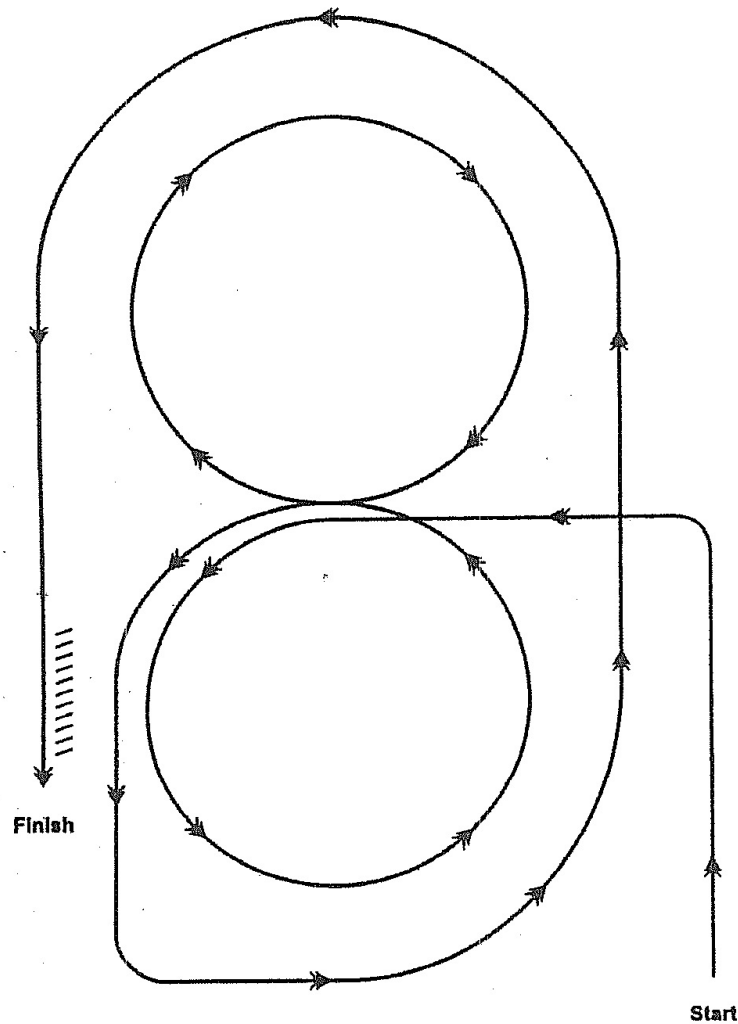

Horseman Pattern 1:

1. Do extended jog along side of arena, then to center
2. Begin lope at center of arena and lope left circle on left lead
3. Change leads at center of arena and lope right circle on right lead
4. Change leads and continue loping around end of arena
5. Once on the straight, increase speed and continue around end of arena
6. Stop and back
7. The MRAI Judges Committee reserves the right to make alterations and/or additions to this pattern.

Pattern 2

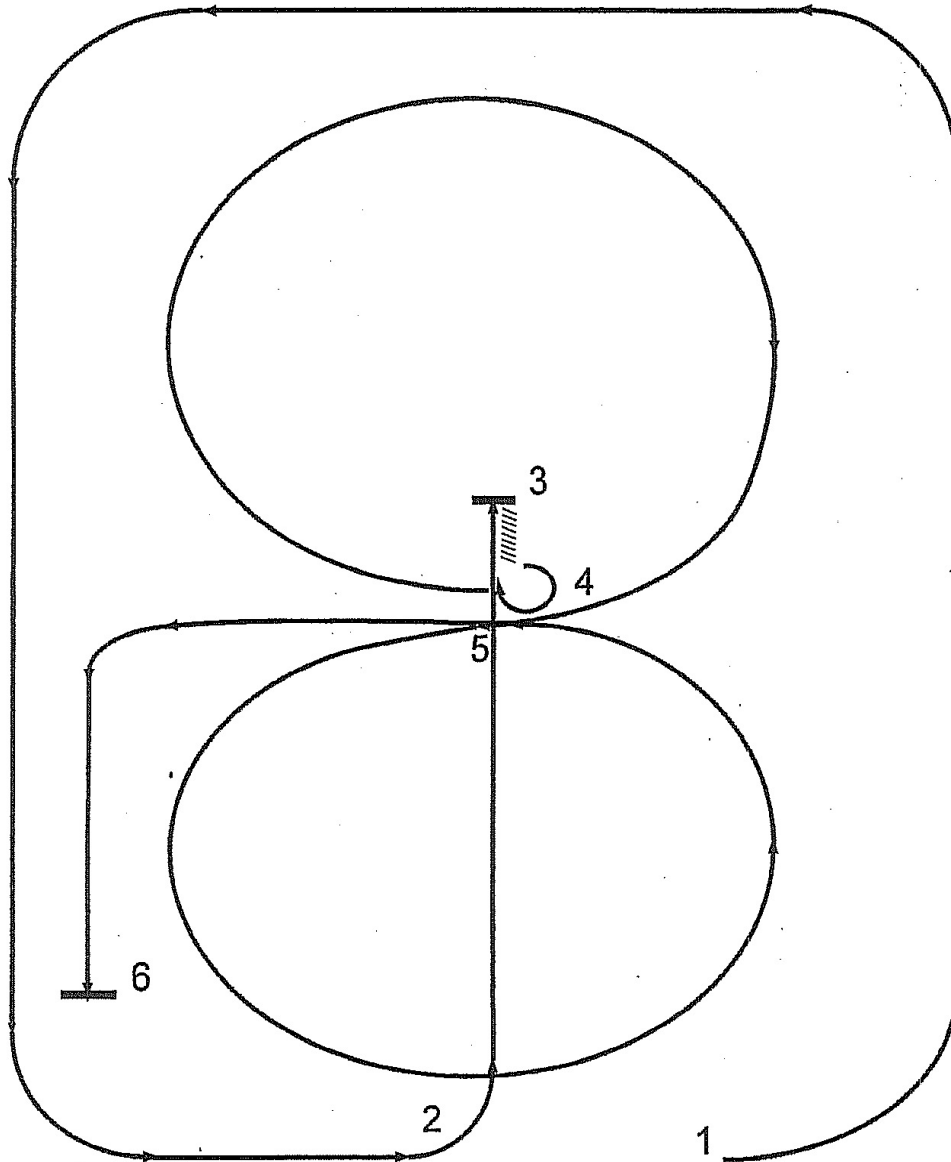

Horsemanship Pattern 2:

1. Circle the arena, on the left lead, at an extended lope.
2. Guide left and lope down the center of the arena with moderate speed.
3. Pass the center of the arena, stop and back to the center.
4. Execute a 3/4 turn to the right and lope a circle, to the right, with moderate speed.
5. Change leads and lope a circle, to the left, with moderate speed. After completing the circle, continue loping on the left lead toward the end of the arena.
6. Stop and pause to show completion of pattern.

Pattern 3

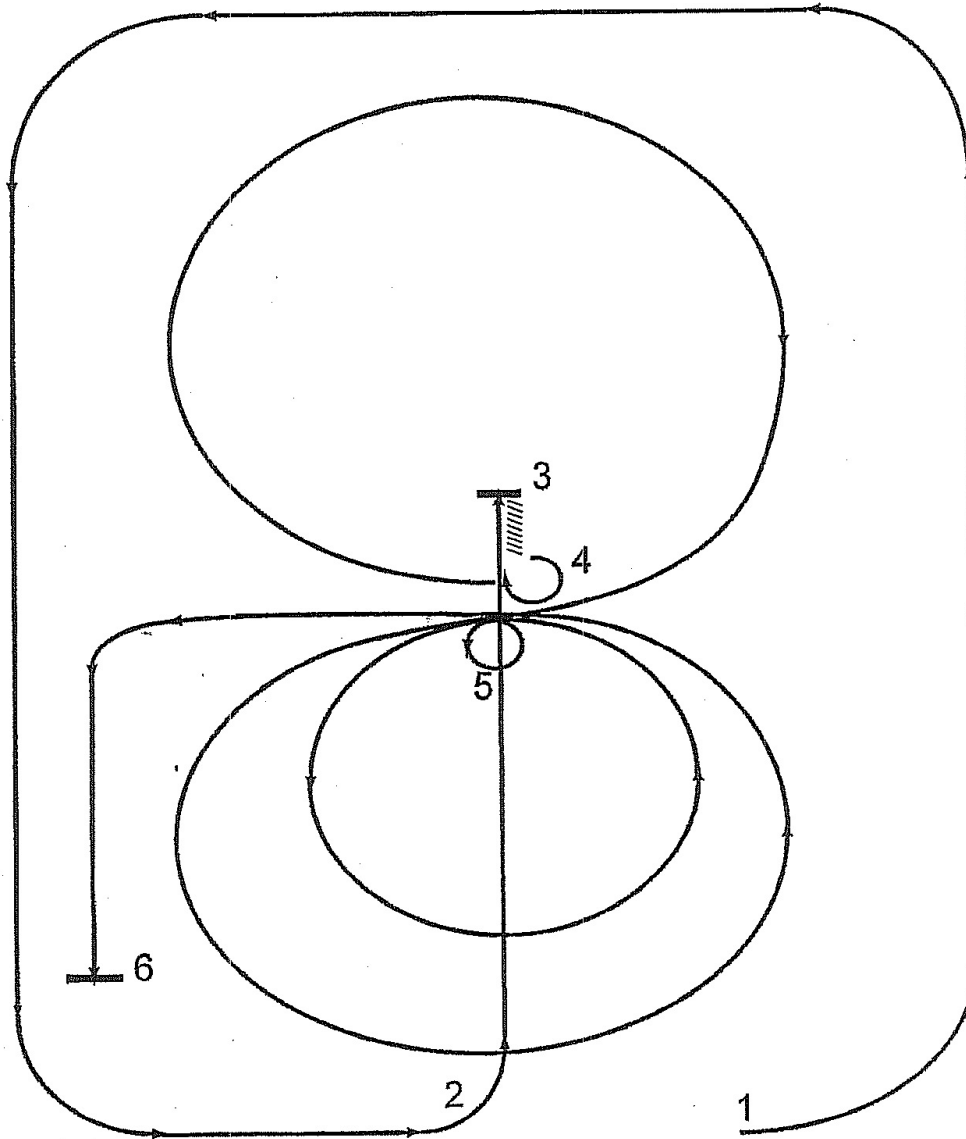

Horsemanship Pattern 3:

1. Circle the arena, on the left lead, at an extended lope.
2. Guide left and lope down the center of the arena with moderate speed.
3. Pass the center of the arena, stop and back to the center.
4. Execute a 3/4 turn to the right and lope a circle, to the right, with moderate speed.
5. Stop in the center, execute a 360 degree turn, to the left. Lope a small slow circle, to the left, followed by a larger, faster circle to the left. At the center of the arena, rate back to the slower speed and continue loping on the left lead toward the end of the arena.
6. Stop and pause to show completion of pattern.